

ELEVATION / ANSICHT

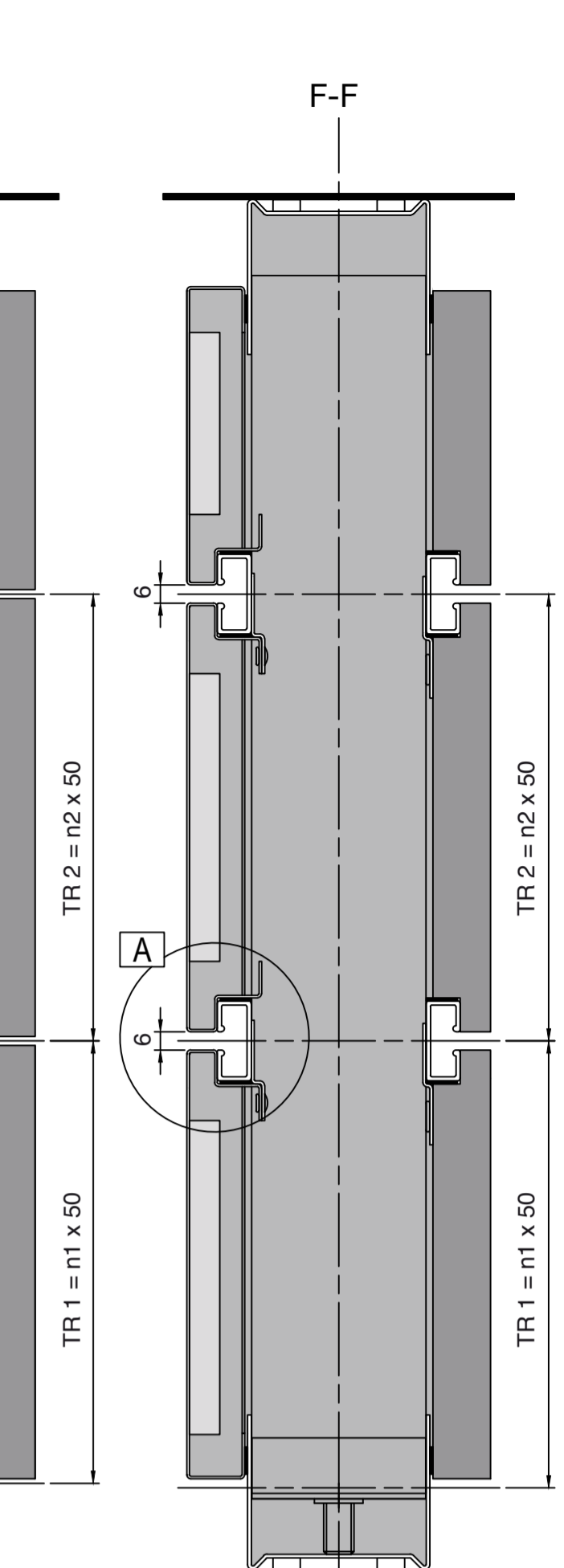
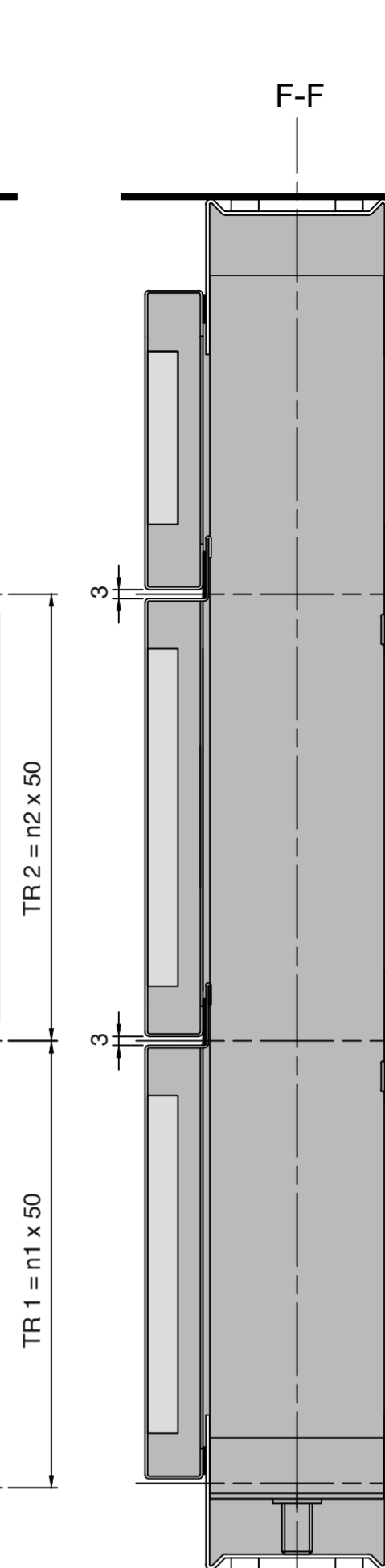
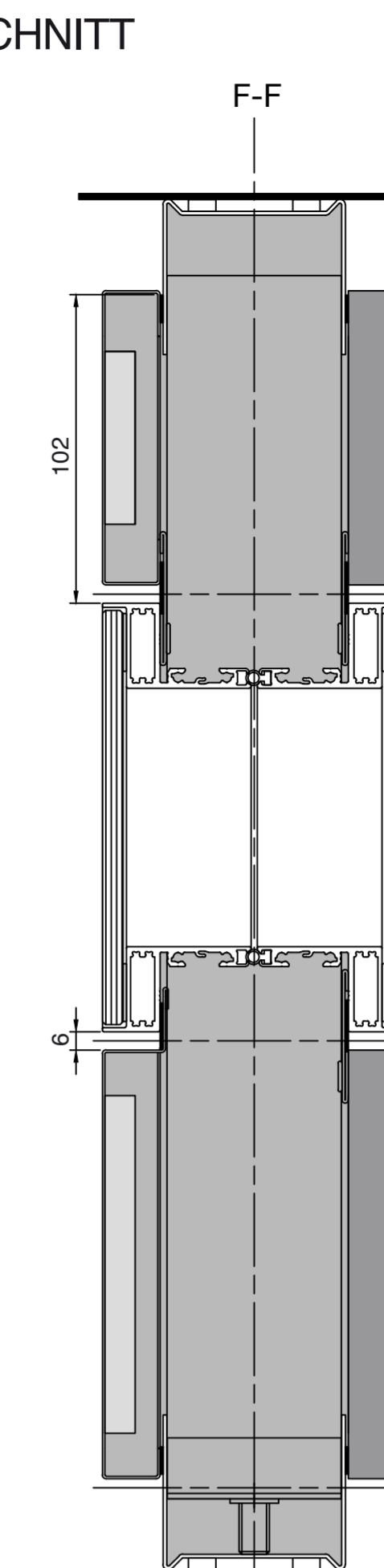
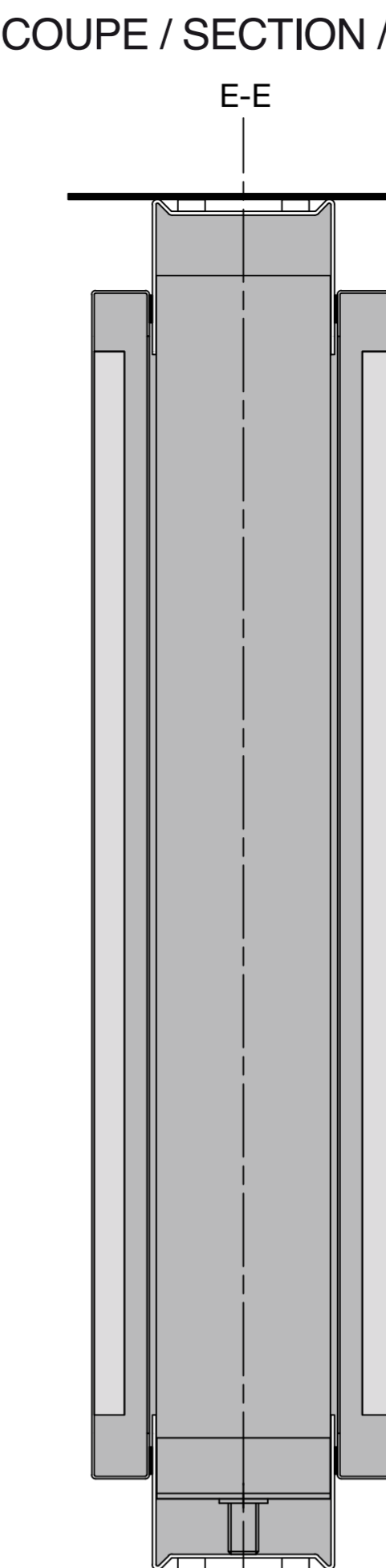
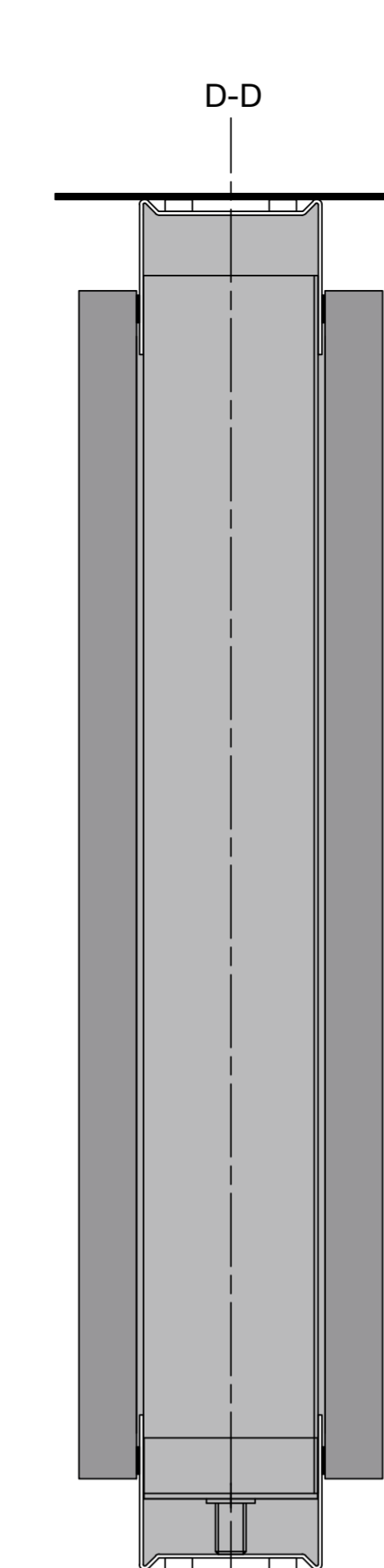
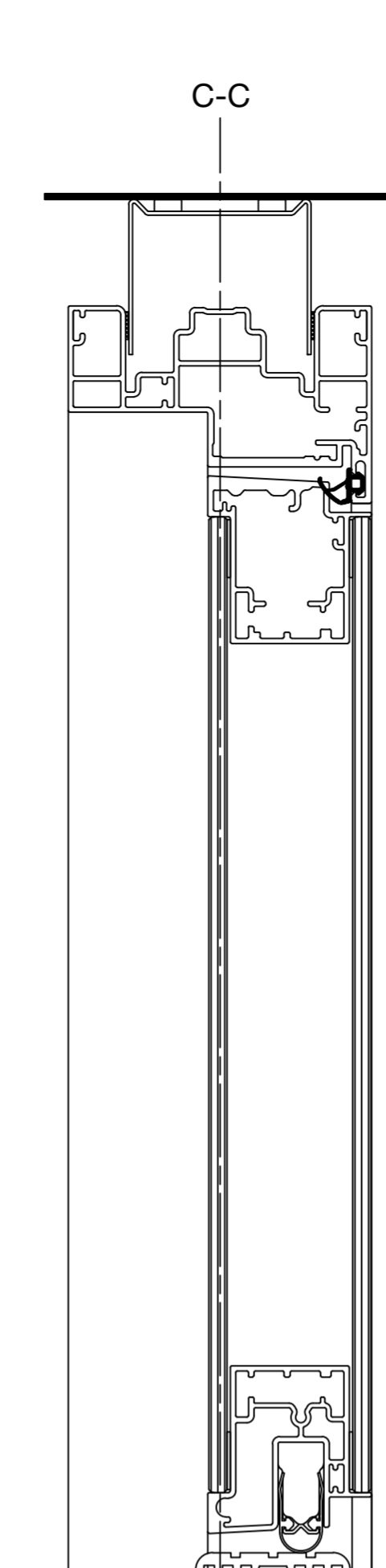
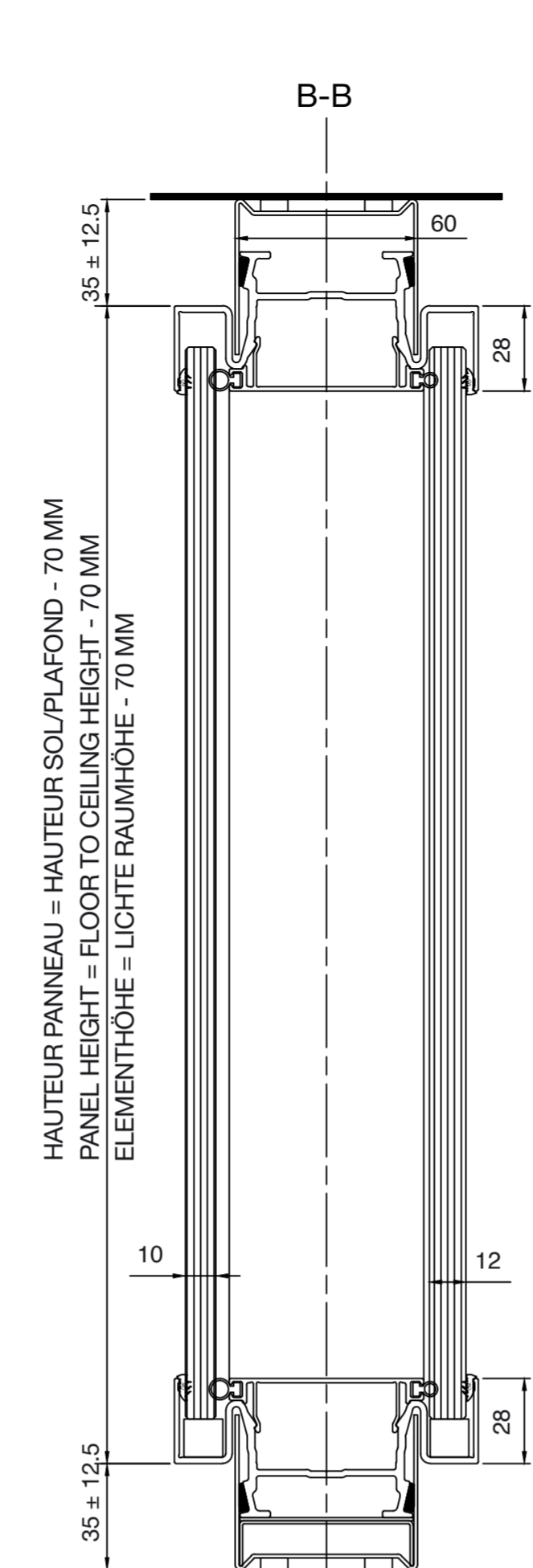
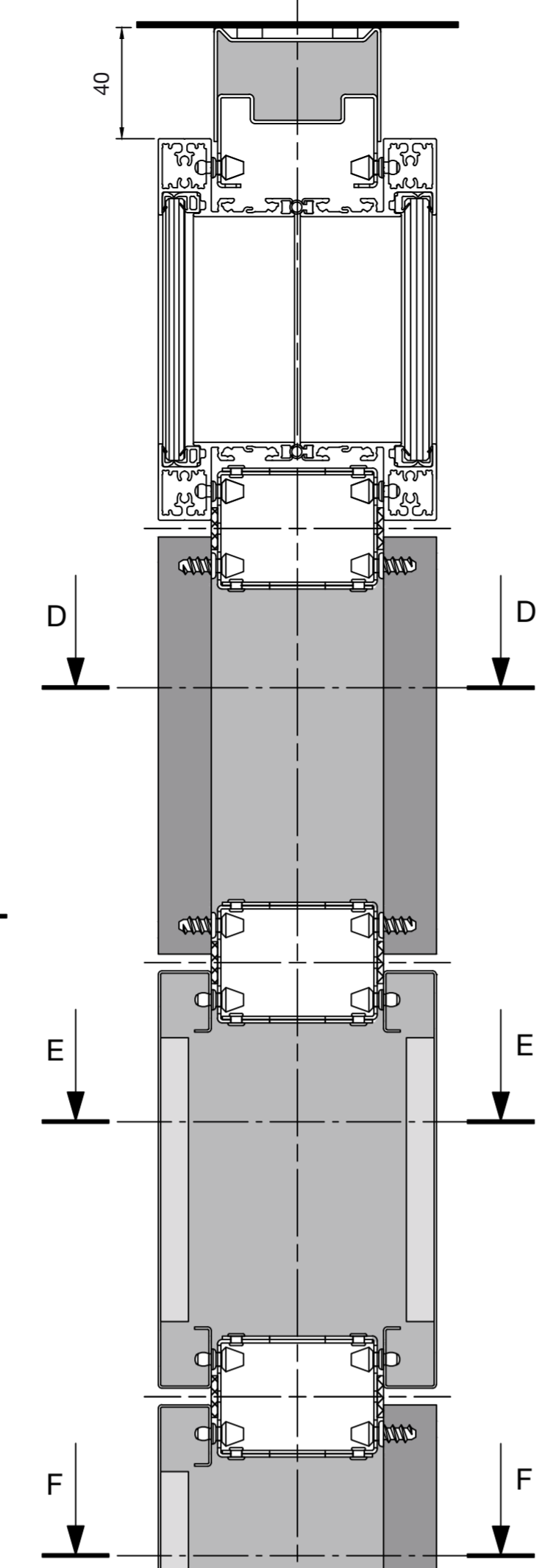
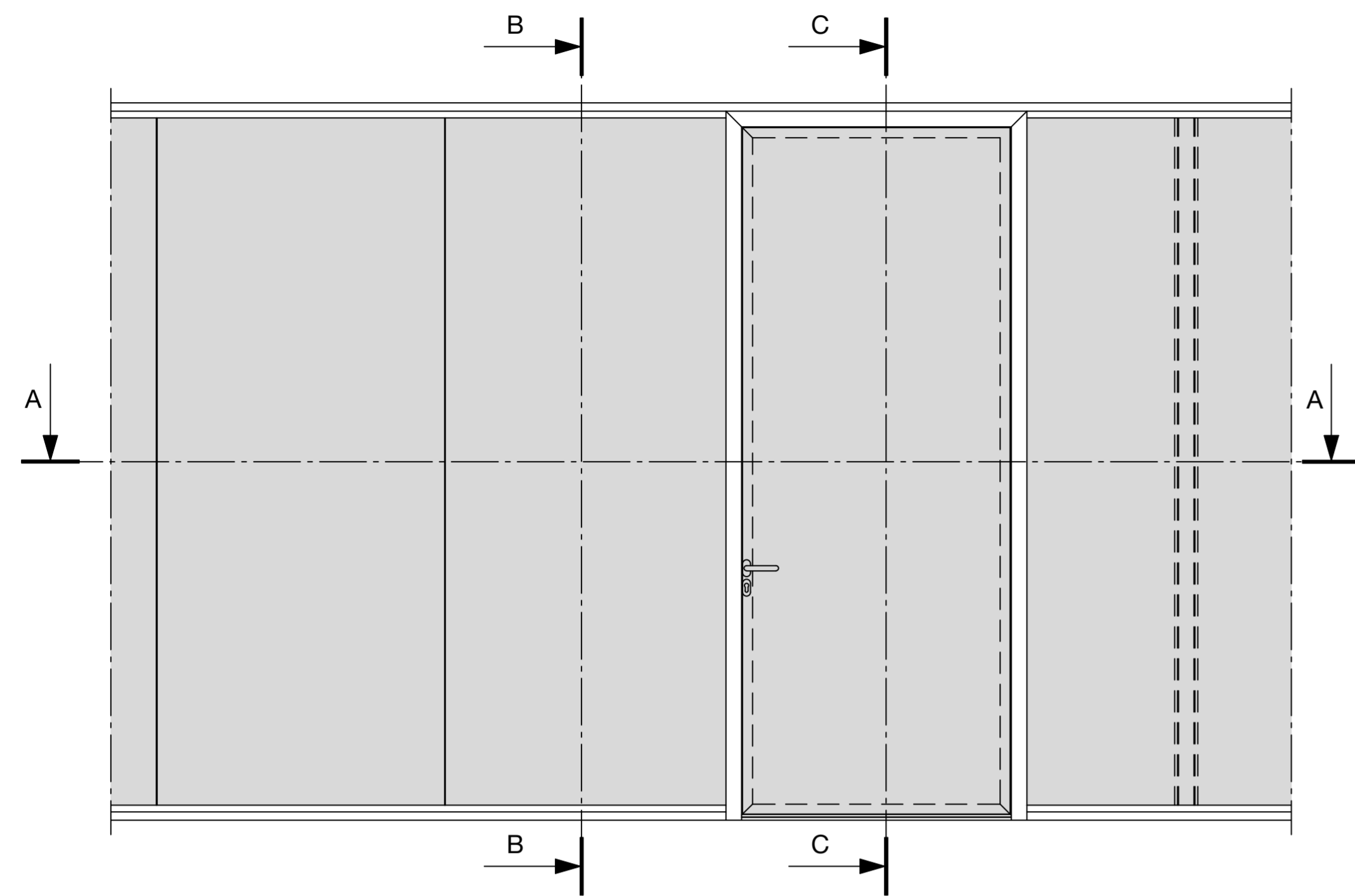

HAUTEUR PANNEAU = HAUTEUR SOL/PLAFOND - 70 MM
 PANEL HEIGHT = FLOOR TO CEILING HEIGHT - 70 MM
 ELEMENTHÖHE = LICHTE RAUMHÖHE - 70 MM

COUPE / SECTION / SCHNITT

COUPE / SECTION / SCHNITT A - A

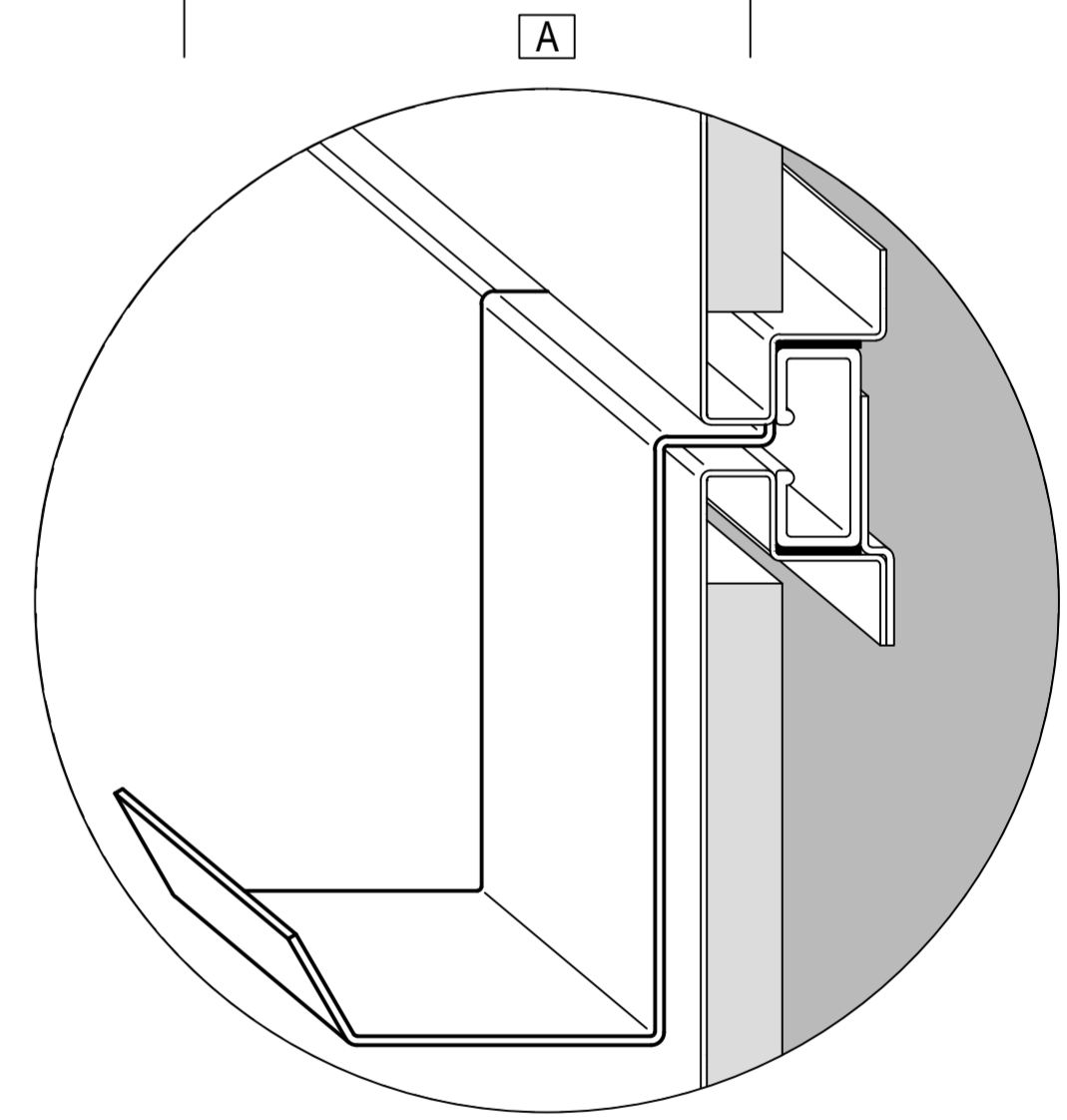
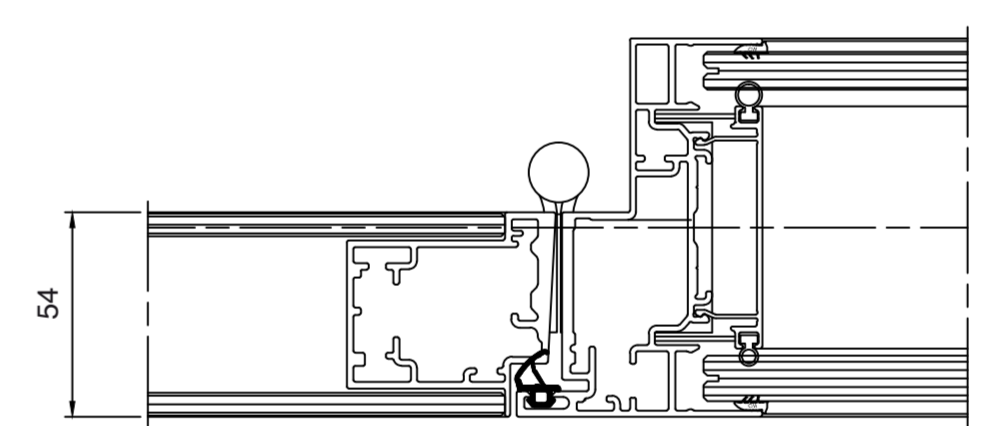
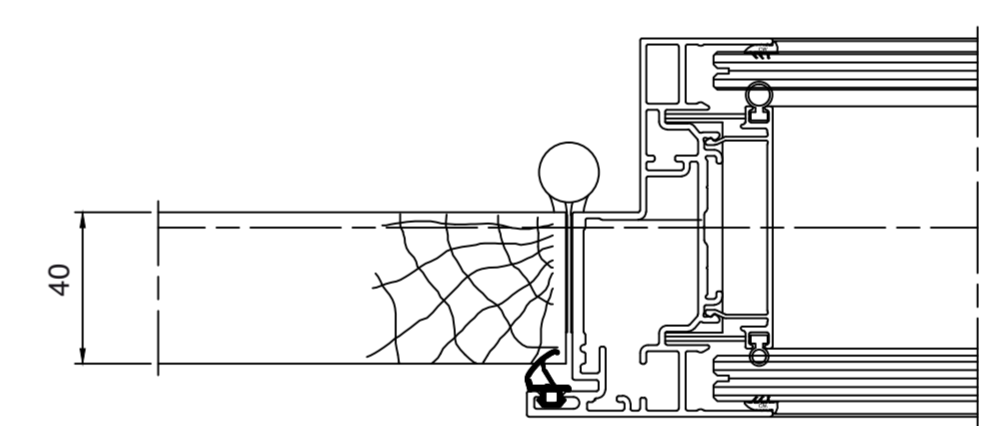
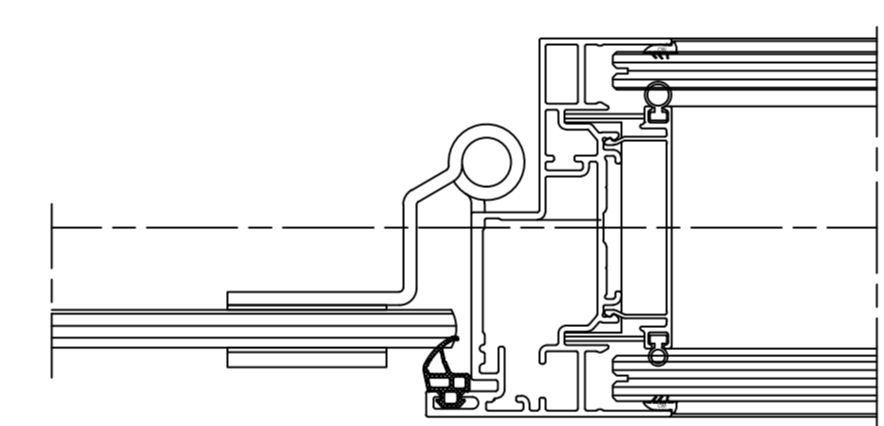
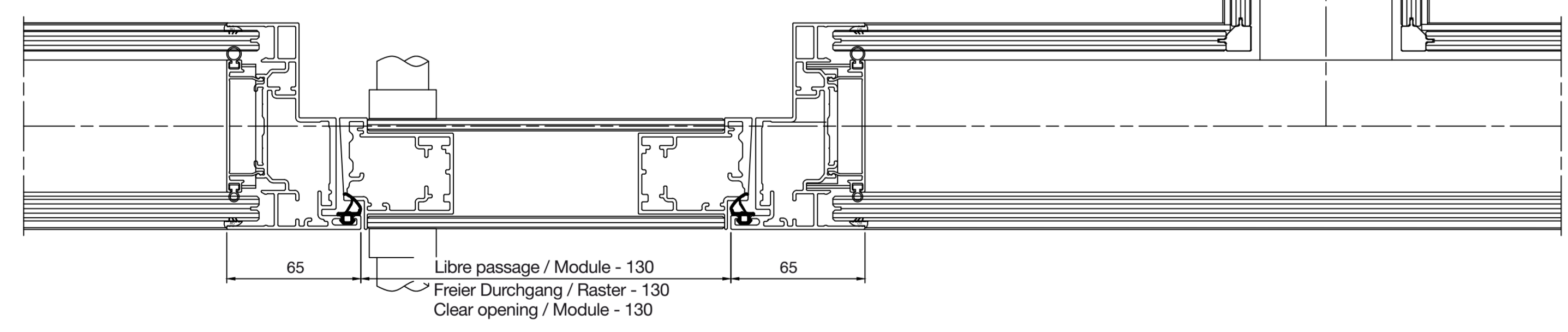

ABR

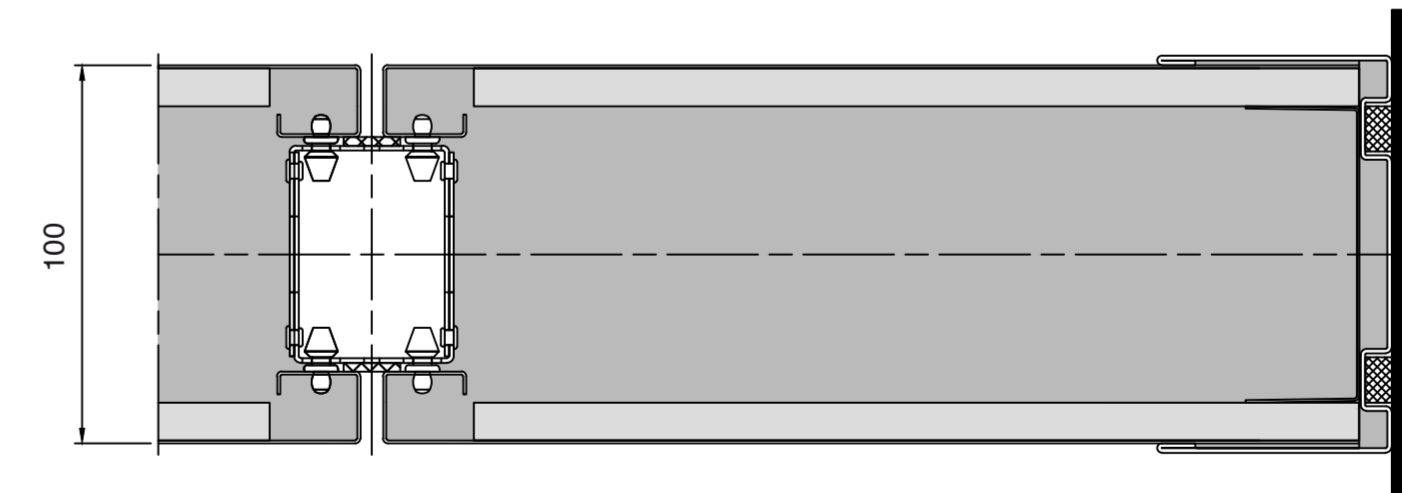

JONCTIONS / JUNCTIONS / KNOTENPUNKTE

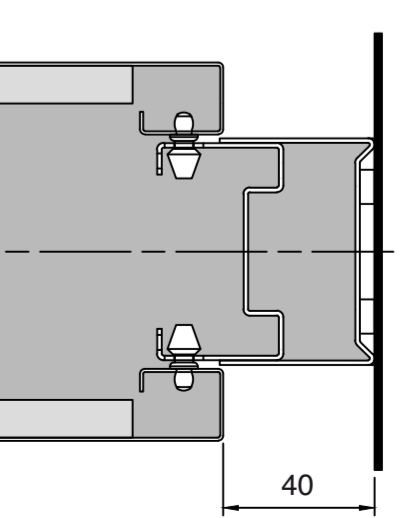
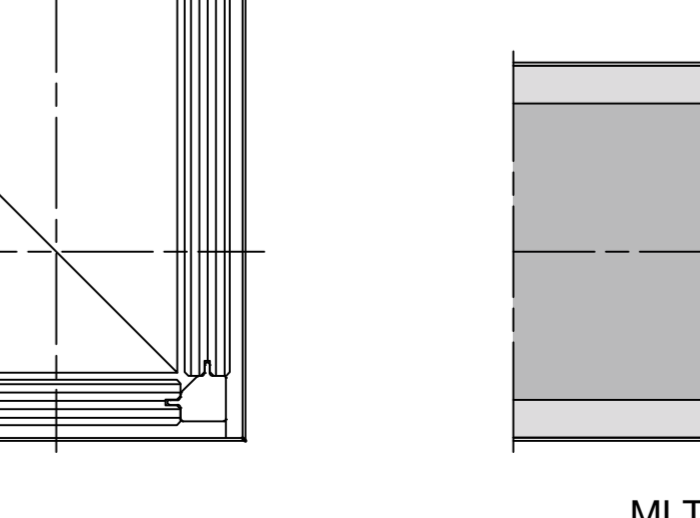
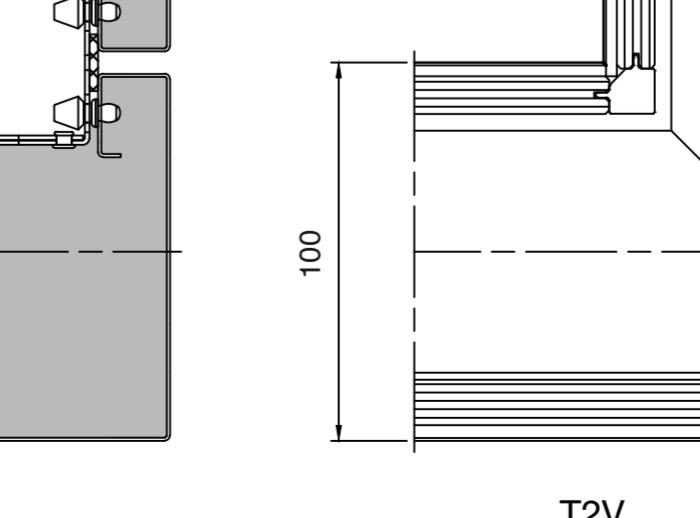
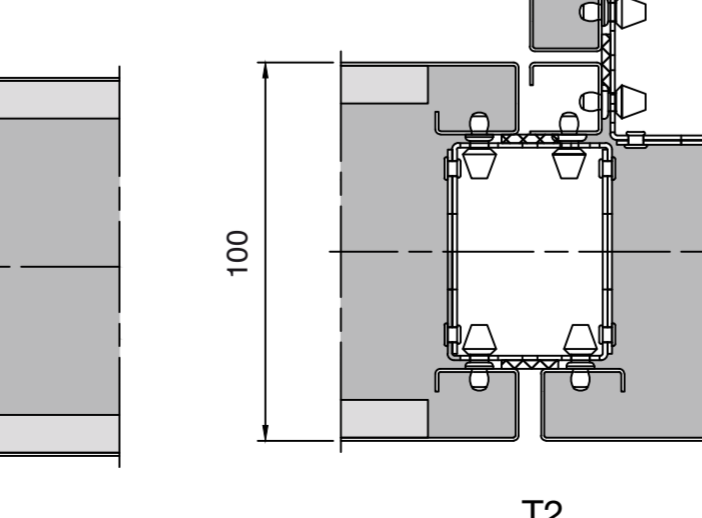
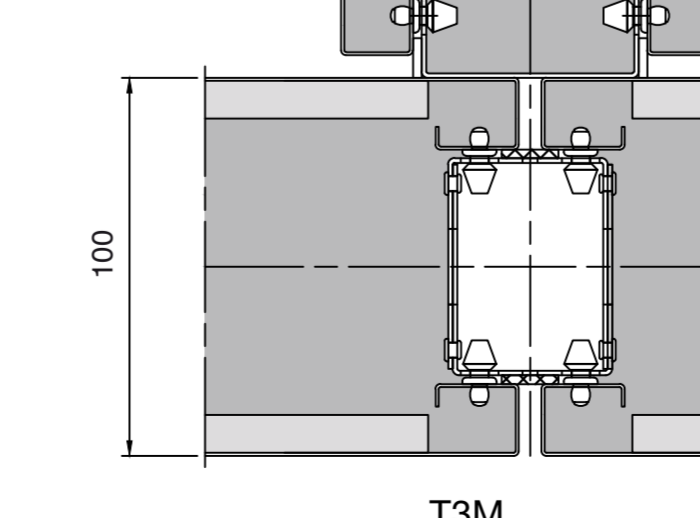
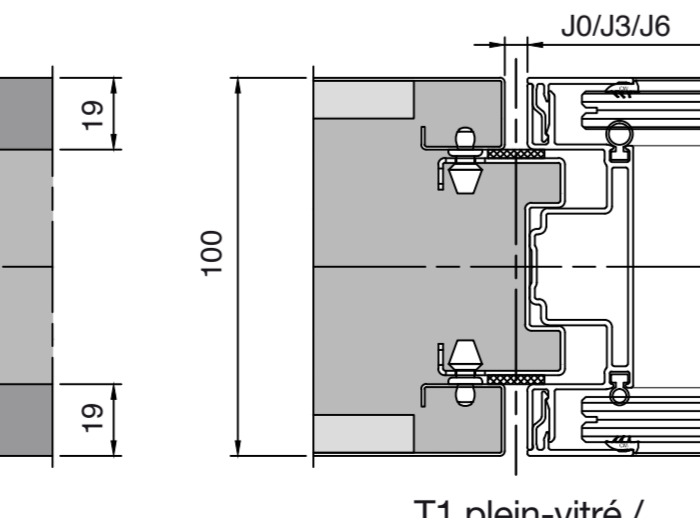
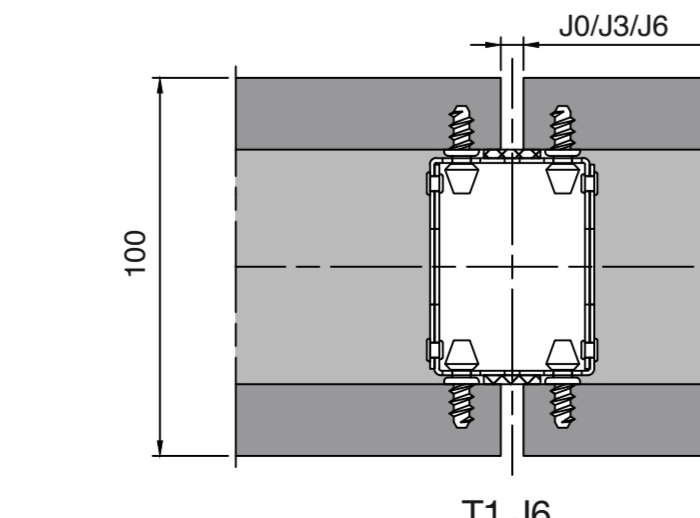
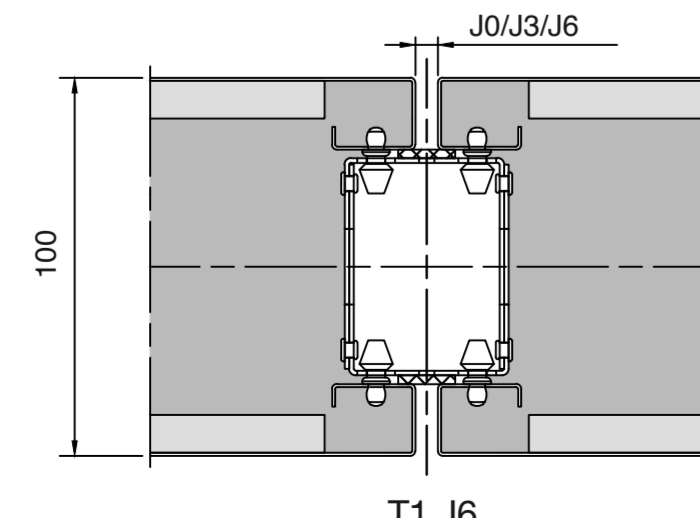
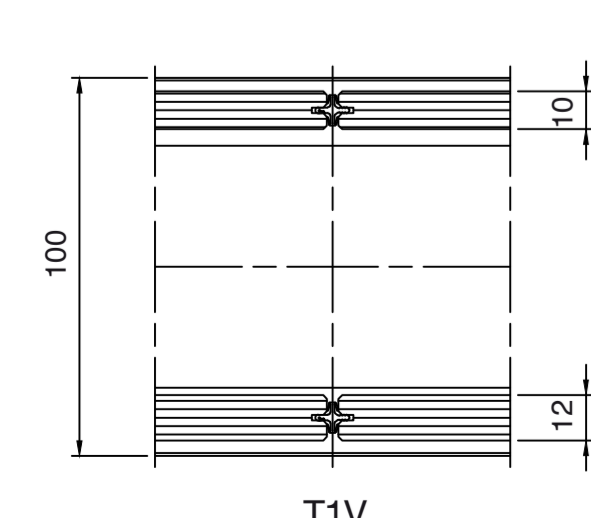

CLESTRA SE RÉSERVE LE DROIT D'APPORTER, SANS PRÉAVIS, DES MODIFICATIONS TECHNIQUES N'ALTÉRANT PAS LA QUALITÉ DU PRODUIT.
 CLESTRA BEHÄLT SICH DAS RECHT VON TECHNISCHE ÄNDERUNGEN VORZUNEHMEN, OHNE DIE QUALITÄT DES PRODUKTES ZU ÄNDERN.
 CLESTRA RESERVES THE RIGHT TO MAKE SUCH ALTERATIONS IN DESIGN AND MANUFACTURE WHICH ARE CONSIDERED NECESSARY AS A RESULT OF PRODUCT DEVELOPMENT, WITHOUT NOTICE.

CLESTRA	
Métropolines M2	PLAN DE PRINCIPE BASIC DRAWING PRINZIPZEICHNUNG
DATE: 09/12	ECHELLE: 1/2
DATUM:	SCALE: MASS-STAB: